



2022-2023

## **TABLE OF CONTENTS**

Principal Message	3	Plan CCR	26
Administration/Counselors	4	Class Changes	26
Phone Numbers	4	Testing	27
Student Body Officers' Message	5	Parent Teacher Student Assoc.	27
Student Body Officers	6	Step2TheU	28
School Song	8	Work Based Learning	
School Dances	8	Student Clubs & Organizations	32
School Map	9	Report Cards	33
Bell Schedule	10	Visitors	33
22-23 School Calendar	11		33
Student Engagement	12		
Alta Hawks Soar	13		
Attendance Policy	14		
Student Policies	19		
Athletics/Region VII			
Parking			
Hall Passes	20		
Insurance	20		
Lockers	20		
Lost and Found	20		
Check and Change Policy	21		
Fines	21		
Refunds	21		
School Lunch	22		
College/Career Ready Timeline	23		
Graduation Requirements	24		
Advanced/Honors Diploma	25		

Alta High School  
11055 South 1000  
East  
Sandy, Utah 84094

Dear Alta Student,

Welcome to Alta High School, "Home of the Hawks!"

We are excited and thrilled that you have chosen to be a part of our school family. Alta High School has many rich traditions of excellence that you will have the opportunity to become a part of. We make great efforts to provide an inclusive learning community with a deep tradition of inspiring, supporting, and collaborating with our students to help each of you prepare for your future.

Our primary goal is to help you gain knowledge, skills, and positive traits that will help you become college-and-career ready. We will do everything we can to prepare you to be successful in the 21<sup>st</sup> century. As an Alta Hawk, we expect you to **SOAR** both during and after your time here in the "nest!"

Alta Hawks **SOAR** by being **Safe**, **Organized**, **Actively Engaged**, and **Respectful**. We provide a **SOARING** environment by working and collaborating together in our classrooms, hallways and commons, activities, and in our broader community. As an Alta Hawk, you are a representative and an ambassador for our school. You will now represent the thousands of alumni that have attended this fine institution of learning. We know you are ready for the challenge and responsibility, and that you will SOAR during your high school years here at Alta and beyond.

Thank you for your enthusiasm, excitement, loyalty, and commitment to Alta High School. We have high expectations for you and encourage you to become actively engaged and involved here at Alta. We challenge you to make several positive contributions to your school, and continue to add to the foundation of making Alta High School a tremendous school and community!

I formally welcome you to Alta High School and look forward to working with each of you and getting to know you. It is a great day to be a HAWK!

Sincerely,

*Kenneth A. Rowley*

Principal

## **Administration**

### **Principal**

Kenneth Rowley

### **Assistant Principals**

Melissa Lister	A-D
Shelly Karren	E-K
Jared Tucker	L-R
Kalisi Uluave	S-Z

## **Comprehensive Guidance**

### **Counselors**

Jennifer Scheffner	A - Ch
Christine Astle	Ci - Gd
Sandy White	Ge - Kh
Cierra Bell Johnson	Ki - O
Callie Bjerregaard	P - So
Lisa Ballash	Sp - Z
	Special Projects

### **CTE Coordinator**

Brandon Jacobson

### **School Psychologist**

Alicia Hoerner

### **LCSW**

Shad Roundy

## **Phone Numbers**

Main Office	801-826-5600
Main Office Fax	801-826-5609
Attendance Office	801-826-5610
Counseling Center	801-826-5620
Counseling Center Fax	801-826-5698

## 2022-2023 Theme

???

## 2022-2023 Welcome Letter

Dear Fellow Hawks,

We feel honored to welcome you to the Alta Family, and we hope you come to love this school as much as we do. Alta High School can be a place of tremendous growth if you take advantage of the many opportunities available to you.

As we embark on this upcoming school year, we encourage everyone to make the most of your limited time here. High school gives you the incredible chance to make enduring friendships, create lasting memories, and gain valuable skills. We challenge everyone to take part in the Alta spirit, and discover what it means to each of you to "Ignite the Hawk Within". We are so excited to experience everything that this year has in store for Alta. We love you, and we can't wait for the amazing things to come.

Sincerely, Your 2022-2023 SBOs

## Student Government

Student body officers include president, vice president, secretary, financial chairperson, attorney general, historian, public relations chairperson, women's activity chairperson, and men's activity chairperson. They organize activities for the student body. Class officers include president, vice president, secretary, historian, and public relations. Students running for Student Government must exemplify all aspects of the Student Code of Conduct. Elected officers or candidates who violate the Student Code of Conduct may be removed or excluded from participation in Student Government.

## 2022-2023 Alta Student Government

### Student Body Officers

Samuel K. Strong	President
Ellie M. Anderson	Vice-President
Aysha M. Sauk	Secretary
Katelyn M. Davis	Historian
Bronson C. Adams	Attorney General
Luke C. Vickery	Financial Chair
Jackson T. Christensen	Public Relations
Carter J. Wray	Chief of Activities
Gabriel J. Crestani	Audio/Visual Officer

### Senior Class Officers

Anderson Da Silva	President
Parker Fenton	Vice-President
Ella Rees	Secretary
Zachary Graham	Historian
Joshua Bingham	Public Relations

### Senior Senators

Jessie Lyons	Head Senator
Johnny Nu'usila	Senator
Anne Okerlund	Senator
Seurette Relyea	Senator
Gage Wesemann	Senator
Kelsey Gardner	Head Cheerleader
Eden Merrill	Head Cheerleader

### Junior Class Officers

Dallen Jeppson	President
Lucas Groscost	Vice President
Joseph Butler	Secretary
Marshall Young	Historian
Bode Rockwood	Public Relations
Jorja Smith	Senator

**Sophomore Class Officers**

Autumn Engstrom	President
Jordan Cai	Vice President
Luke Bjerregaard	Secretary
Jake Johnson	Historian
Justice Cole	Public Relations
Chloe Chytraus	Senator

**Freshman Class Officers**

TBA	President
TBA	Vice President
TBA	Secretary
TBA	Historian
TBA	Public Relations
TBA	Senator

## **Alta School Song**

**Stand up for Alta High**

**Our Hawks soar to the sky**

**Our spirit's high, that is the key**

**To lead our team to victory**

**A-L-T-A Alta Hawks are here to stay**

**Our black and silver in the sun**

**Will show that we're number one!!**

**Take pride in all we do**

**Success will follow you**

**We set our goals**

**We will achieve**

**And proud traditions we shall leave**

**A-L-T-A H-A-W-K**

**Forever more they'll hear our cry**

**The Hawks of Alta High**

## 2022-2023 School Dances

***ID cards are required for all dances and school dress code will be enforced.***

<b>DANCE</b>	<b>DAY/DATE</b>	<b>TIME</b>	<b>PLACE</b>	<b>DRESS</b>	<b>CHOICE</b>	
OPENING HELLO STOMP	Saturday, August 20	8:30 -10pm	A	Casual	Stagg	Alta students only
HOMECOMING	Saturday, October 8	8-10 pm		Semi-Formal	Boys Choice	
RED RODEO DANCE	Saturday, November 5	7-8 pm		Casual/ Theme Dress	Girls Choice	
WINTER CHARITY DANCE	Saturday, December 3	7-9 pm		Casual/ Theme Dress	Boys Choice	
SWEETHEARTS	Saturday, February 4	7-9 pm		Semi-Formal	Girls Choice	
PROM	Saturday, March 18	8:30-10:30pm	Capital	Formal/Semi-Formal	Boy's/Any Junior Choice	
GIRLS PREFERENCE (Pref.)	Saturday, April 15	8-10 pm		Casual/Theme	Girls Choice	
CLOSING STOMP						
SENIOR DINNER DANCE	Friday, May 15	6-10 pm	Living Planet Aquarium Draper UT	Semi-Formal	Stagg	Alta Seniors Only

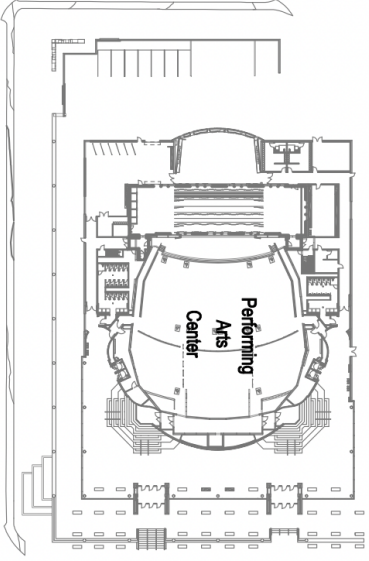
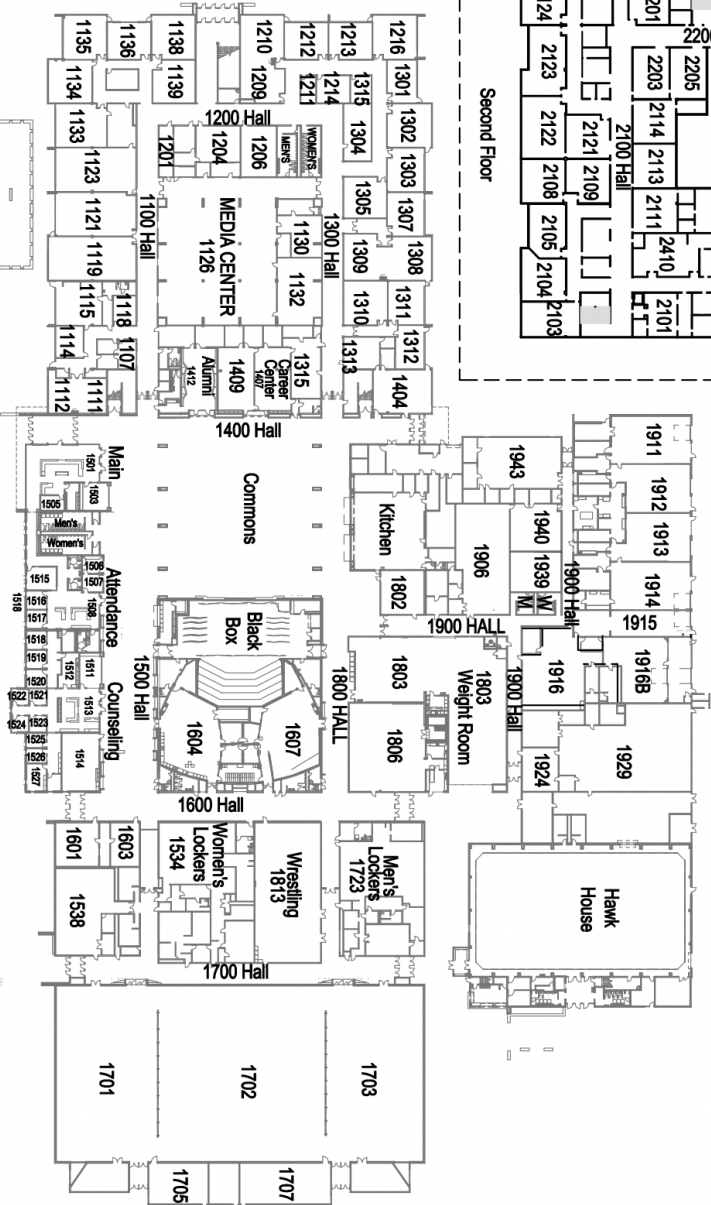
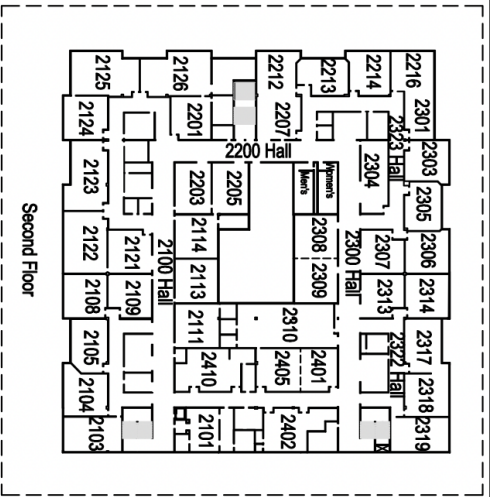

**ALTA**

**HIGH SCHOOL**



## Canyons School District 2022-2023 School Calendar K-12

August							September							October								
S	M	T	W	T	F	S	S	M	T	W	T	F	S	S	M	T	W	T	F	S		
	1	2	3	4	5	6						1	2	3							1	
7	8	9	10	11	12	13	4	5	6	7	8	9	10	2	3	4	5	6	7	8		
14	15	16	17	18	19	20	11	12	13	14	15	16	17	9	10	11	12	13	14	15		
21	22	23	24	25	26	27	18	19	20	21	22	23	24	16	17	18	19	20	21	22		
28	29	30	31				25	26	27	28	29	30		23	24	25	26	27	28	29		
														30	31							
November							December							January								
S	M	T	W	T	F	S	S	M	T	W	T	F	S	S	M	T	W	T	F	S		
		1	2	3	4	5						1	2	3		1	2	3	4	5	6	7
6	7	8	9	10	*11	12	4	5	6	7	8	9	10	8	9	10	11	12	13	14		
13	14	15	16	17	18	19	11	12	13	14	15	16	17	15	16	17	18	19	20	21		
20	21	22	23	24	25	26	18	19	20	21	22	23	24	22	23	24	25	26	27	28		
27	28	29	30				25	26	27	28	29	30	31	29	30	31						
February							March							April								
S	M	T	W	T	F	S	S	M	T	W	T	F	S	S	M	T	W	T	F	S		
			1	2	3	4				1	2	3	4		1	2	3	4	5	6	7	8
5	6	7	8	9	10	11	5	6	7	8	9	10	11	2	3	4	5	6	7	8		
12	13	14	15	16	17	18	12	13	14	15	16	17	18	9	10	11	12	13	14	15		
19	20	21	22	23	24	25	19	20	21	22	23	24	25	16	17	18	19	20	21	22		
26	27	*28					26	27	28	29	30	31		23	24	25	26	27	28	29		
														30								
May							June															
S	M	T	W	T	F	S	S	M	T	W	T	F	S									
	1	2	3	4	5	6					1	2	3									
7	8	9	10	11	12	13	4	5	6	7	8	9	10									
14	15	16	17	18	19	20	11	12	13	14	15	16	17									
21	22	23	24	25	26	27	18	19	20	21	22	23	24									
28	29	30	31				25	26	27	28	29	30										

Note: School emergency closure days will be made up by scheduling remote learning day(s)

- Teachers at School
- Start and End of School Year
- No Student Day
- Parent/Teacher Conferences
- First Day of School for Kindergarten
- K-5 Trimester End
- 6-12 Quarter End

Red A Day  
Black B day

- Teachers at School Aug 8-12
- First Day of School Aug 15
- First Day of School for Kindergarten Aug 18
- Labor Day Recess Sept 5
- Parent/Teacher Conferences High Schools Sept 26-27
- Parent/Teacher Conferences Middle Schools Sept 27-28
- Parent/Teacher Conferences Elementary Schools Sept 28, 29
- Early Out Elementary Sept. 29
- No Student Day (Compensatory Day) Sept. 30
- End of 1st Quarter Grades 6-12 Oct 19
- Fall Recess Oct 20, 21
- End of 1st Trimester K-5 Nov 11
- Thanksgiving Recess Nov 23-25
- Winter Recess Dec 19- Jan 2
- End of 2nd Quarter Grades 6-12 Jan 12
- Grading Day Grades K-12 Jan 13
- Martin Luther King Jr. Day Recess Jan 16
- Presidents' Day Recess Feb 20
- Parent/Teacher Conferences Middle Schools Feb 27, 28
- End of 2nd Trimester K-5 Feb 28
- Parent/Teacher Conferences High Schools Feb 28, Mar 1
- Parent/Teacher Conferences Elementary Schools Mar 1, 2
- Early Out Elementary Mar 2
- No Student Day (Compensatory Day) Mar 3
- End of 3rd Quarter Grades 6-12 Mar 17
- Spring Recess Apr 3-7
- End of School May 26
- Every Friday is an Early Out Day for all Schools
- Elementary early out Sept 29 and March 2
- This calendar is not for Brighton Students

## Alta High School Bell Schedules 2022 - 2023

Mon., Tues., Wed., Thurs. Schedule	
<b>Engagement Time</b>	<b>7:10 – 7:40</b>
<b>1<sup>st</sup> Period / 5<sup>th</sup> Period</b>	<b>7:45 – 9:05</b>
<b>Advisory Period</b>	<b>9:10 – 9:40</b>
<b>2<sup>nd</sup> Period/ 6<sup>th</sup> Period</b>	<b>9:45 – 11:05</b>
<b>1<sup>st</sup> Lunch</b>	<b>11:05 – 11:35</b>
<b>3<sup>rd</sup> Period / 7<sup>th</sup> Period</b>	<b>11:10 – 12:30</b>
<b>3<sup>rd</sup> Period / 7<sup>th</sup> Period</b>	<b>11:40 – 1:00</b>
<b>2<sup>nd</sup> Lunch</b>	<b>12:30 – 1:00</b>
<b>4<sup>th</sup> Period / 8<sup>th</sup> Period</b>	<b>1:05 – 2:25</b>

Friday Schedule	
<b>Engagement Time</b>	<b>7:10 – 7:40</b>
<b>1<sup>st</sup> Period / 5<sup>th</sup> Period</b>	<b>7:45 – 8:50</b>
<b>NO ADVISORY</b>	<b>-----</b>
<b>2<sup>nd</sup> Period/ 6<sup>th</sup> Period</b>	<b>8:55 – 10:00</b>
<b>3<sup>rd</sup> Period / 7<sup>th</sup> Period</b>	<b>10:05 – 11:10</b>
<b>4<sup>th</sup> Period / 8<sup>th</sup> Period</b>	<b>11:15 – 12:20</b>
<b>Lunch</b>	<b>12:20 – 12:45</b>

60-Minute Assembly Schedule	
<b>Engagement Time</b>	<b>7:10 – 7:40</b>
<b>1<sup>st</sup> Period / 5<sup>th</sup> Period</b>	<b>7:45 – 8:58</b>
<b>Assembly</b>	<b>9:03– 10:03</b>
<b>2<sup>nd</sup> Period/ 6<sup>th</sup> Period</b>	<b>10:08– 11:21</b>
<b>1<sup>st</sup> Lunch</b>	<b>11:21 – 11:51</b>
<b>3<sup>rd</sup> Period / 7<sup>th</sup> Period</b>	<b>11:26 – 12:39</b>
<b>3<sup>rd</sup> Period / 7<sup>th</sup> Period</b>	<b>11:56 – 1:09</b>
<b>2<sup>nd</sup> Lunch</b>	<b>12:39 – 1:09</b>
<b>4<sup>th</sup> Period / 8<sup>th</sup> Period</b>	<b>1:14 – 2:25</b>

## Academic Eligibility for Activities

Those students who represent Alta High School in any competitive activity must be academically eligible according to guidelines established by the Utah High School Activities Association (UHSAA) and Alta High School. In order to participate, a student must:

NOT have received more than (1) one failing grade and have at least a 2.0 GPA from the previous quarter. **Fall sports student athletes your 4<sup>th</sup> quarter advisory grade is calculated into your GPA, which affects academic eligibility for the first quarter of the next school year.** For further information, see the UHSAA handbook and Region VII manual. Violations of the Student Code of Conduct can disqualify athletes from participation.

## Athletics/Region VII

Alta High offers a wide variety of athletic teams. They include: football, basketball, baseball, volleyball, softball, tennis, soccer, track, cross country, golf, wrestling, drill, swimming and lacrosse.

Alta participates in competitive events as a member of the Utah High School Activities Association (UHSAA). Alta is a 5A school and participates under the Region VII guidelines of the UHSAA. The schools in Region VII are as follows:

Alta	11055 S. 1000 E.	801-826-5600
Lehi	180 N. 500 E	801-610-8805
Timpanogos	1450 N. 200 E. Orem	801-610-8175
Mountain View	665 W. Center St. Orem	801-610-8160
Orem	175 S. 400 E. Orem	801-610-8165
Timpview	3570 N. Timpview Dr.	801-221-9720

## Ticket Prices for Region VII Activities

Student at home games: free **with** activity card/student ID

Students at away games or without activity card: \$5.00

All Children over age of 5 - \$5.00

Adults: \$5.00, Family Pass \$20.00 / game (**limit 6 immediate family members per pass**)

Senior Citizens over 65 and Children under 5 free

Home Basketball Family Pass \$100.00 (**limit 6 immediate family members per pass**)

At Alta many of our teams qualify for State Competition. In most cases the competition times are after school. However, in the event a State Semi-Final or Championship game or activity occurs during school hours, students will be excused to watch the event if the procedure listed below is followed:

1. An "Activity Release Form" for the event must be signed by a parent, returned to the Main Office, and a game ticket purchased.
2. Ticket prices for State activities vary with each activity. Students will NOT be admitted to State events free with activity cards

## **Alta High School Attendance Policy 2022-2023**

Alta High School is an inclusive learning community devoted to the highest levels of academic achievement and performance. In accord with Canyons School District's mission, AHS's priority is to ensure that all students graduate college and career ready through successful pursuit of post-secondary education. Research has demonstrated that attendance in school is one of the strongest predictors for academic achievement and success in the classroom (i.e. participation, critical thinking, effective communication, rehearsing, reciting, and receiving immediate feedback).

The educational foundation for both school and lifelong learning begins with attendance and participation in class and developing a positive rapport with teachers. The educational process requires continuity of both instruction and ongoing learning. Frequent and routine absence from the day-to-day learning environment can significantly impede and disrupt student achievement and success in school, both short and long term. Excellent attendance establishes a pattern of responsibility, accountability, and shows commitment that ultimately will benefit students in high school, post-secondary education, in a career path, and in life.

The Utah Compulsory Attendance law (53A-11-101), and CSD's attendance policy (AA432), directs parents to require their children between the ages of six to eighteen to attend every official school day and for schools to actively promote regular attendance. Therefore, Alta High School has developed a policy that adheres to Canyons School District's and Utah's legal guidelines. (Ref. Utah Code 53A-15-1403)

### **RESPONSIBILITIES**

#### **STUDENTS**

- Students are expected to be prepared and be on time to class every school day in order to maximize educational opportunities.
- When a student is absent from school for any reason, it is his/her responsibility to contact teachers regarding makeup work. Students should contact their teachers (or consult online class resources) as soon as they return to school in order to makeup missed learning opportunities.
- Students shall follow proper check-in and check-out procedures.
- Students and parents are responsible for tracking their academic progress and attendance by using Skyward on a weekly basis.

## **PARENT/GUARDIAN**

- Utah Compulsory Attendance Law [53A-11-101] requires every school age child to be in school. Parent/Guardian is responsible for his/her

children's regular school attendance.

- When a student is absent from any period during the school day, the parent/guardian shall call the Attendance Office for a GUARDIAN APPROVED ABSENCE or submit a doctor, dental, legal note, or other approved written documentation for an EXCUSED ABSENCE.
- The parent/guardian is responsible for tracking his/her student's academic progress and attendance by using Skyward on a weekly basis.

### **SCHOOL PERSONNEL**

- Teachers are expected to record and verify student attendance daily.
- Teachers shall be in their classrooms on time and shall provide meaningful educational activities every day starting when the bell rings to encourage both attendance and punctuality.
- Teachers will provide a disclosure statement, which will explain expectations for academic grading and class participation.
- Administrators and office personnel will work cooperatively with students and parents/guardians to encourage positive school attendance.
- Parents will be notified via a Skylert message on a daily basis when their student has been reported absent in one or more classes.
- Through Skyward Alta High School will provide parents and students with access to attendance data, which is updated daily.
- Upon request, the Attendance Office shall review and resolve discrepancies in student attendance records.

### **POLICY OVERVIEW**

To earn course credit, a student must attend class consistently. If a student accumulates a total of five (5) or more of any of the following codes (A, G, W, A-VT, and T) per class per quarter, the student will receive a no grade (NG). The no grade indicates the student is passing the class but has lost credit for the class due to unexcused absences and/or tardies. Students clear NG's by selecting from a list of options. A no grade (NG) is not available for those who have failed academically. Failing students will receive an F regardless of their attendance status. Both an NG and an F will result in loss of credit.

**For activity or athletic eligibility, a NG is calculated as a failing grade.**

### **ATTENDANCE CODES**

An absence is defined as any class period that a student did not attend. Students are marked according to the following codes:

**ABSENCE (A):** When a student misses class, the teacher will mark the student absent. These absences will count toward the no grade (NG) policy.

**GUARDIAN APPROVED ABSENCE (G):** An absence approved by a parent/guardian within three days of the absence occurring but without approved written documentation (see EXCUSED ABSENCES) will count toward the no grade (NG) policy.

**TARDY (T):** A student will be marked tardy if he/she arrives to class within the first ten minutes after the starting time of each class period. Students are given five minutes to get from one class to the next and should use their time wisely to arrive on time to class. The tardy code will count towards the no grade (NG) policy.

**WAY LATE (W):** When a student arrives to class any time after the ten minutes allowed for a tardy, the student will be marked as way late. The way late code will count towards the no grade (NG) policy.

**EXCUSED ABSENCES (E):** If a student misses a full day, the parent/guardian shall notify the Attendance Office within three days of the absence. Approved written documentation (i.e. dentist note, doctor note, legal note, obituary, wedding announcement, or other approved documentation) MUST be provided. Excusals shall not be accepted after the three days or for previous quarters. The code for excused absences will not count towards the no grade (NG) policy.

**TRUANCY (A-VT):** If police or school personnel verify an absence as truancy, the absence code (A) will be changed to a truancy code (A-VT). School activities and assemblies that are scheduled during school hours are considered part of the regular school day. Students are required to attend the activity or be in a school-supervised alternate area during said time. The truancy code will count towards the no grade (NG) policy.

**VACATION RELEASE (E-V):** Canyons School District policy allows a student to miss up to ten (10) school days per year for pre-approved vacation release. The parent/guardian gives approval by calling the attendance office prior to the student's leave of absence. It is the responsibility of the student to contact his/her teachers regarding assigned work and grades prior to the leave of absence for a vacation release. Seniors attending college visits need to request a vacation release. The code for vacation will not count towards the no grade (NG) policy.

**SCHOOL ACTIVITY (N):** Students participating in activities sponsored by Alta High School or Canyons School District will be excused administratively. The code for school activities will not count towards the no grade (NG) policy.

**SUSPENSION (S):** When a student is placed on suspension, they are not allowed on school property or to attend school sanctioned activities. The code for suspension will not count towards the no grade (NG) policy.

**HOME & HOSPITAL (E-HH):** Due to medical issues, a student may not be able to attend school for a period of ten days or longer. The parent/guardian should contact the Attendance Office to arrange home and hospital services. The code for home and hospital will not count towards the no grade (NG) policy.

## **CHECK-IN/CHECK-OUT PROCEDURES**

**Check-in:** Students checking in during 1<sup>st</sup>/5<sup>th</sup> period who have approved written documentation (see EXCUSED ABSENCES) should check in at the Attendance Office to receive an EXCUSED (E) code. The code for excused absences will not count towards the no grade (NG) policy.

Students arriving during 1<sup>st</sup>/5<sup>th</sup> period without approved written documentation (see EXCUSED ABSENCES) should go directly to class. The teacher will mark the student tardy (T) if the student arrives within the first ten minutes of class and will mark the student way late (W) if the student arrives after the first ten minutes of class. The tardy (T) and way late (W) codes will count toward the no grade (NG) policy.

If a student enters campus for the first time during any other period throughout the day, a parent/guardian must check-in the student through the Attendance Office. The check-in will be coded as a GUARDIAN APPROVED ABSENCE

(G) unless the parent/guardian provides approved written documentation (see EXCUSED ABSENCES) within three school days. **A parent/guardian may not retroactively check-in his/her student.**

**Check-out:** If it becomes necessary for a student to leave school during the day, the student must check-out through the Attendance Office. A parent/guardian must call the Attendance Office and give permission for the student to check-out. The student will receive a check-out slip from the Attendance Office permitting him/her to leave. The check-out will be coded as a GUARDIAN APPROVED Absence (G) unless the parent provides approved written documentation (see EXCUSED ABSENCES) within 3 school days.

If a student waits to check-out until the last 30 minutes of a period, he/she will be given a check-out slip but will not be given an attendance code or considered absent. When a student has checked out and then returns to school, he/she must check-in with the Attendance Office. **A parent/guardian may not retroactively check-out his/her student.**

## **OPTIONS FOR MAKING UP NG'S & AVOIDING LOSS OF CREDIT**

To clear no grades (NG) students must clear all attendance marks above the four allowed by selecting from the options listed below. To do so, a student must pick up a form in the Attendance Office and/or attend Hawk Study Hall for each no grade (NG). 60 minutes of time will modify one absence (A, G, W, AVT) and 30 minutes of time will

modify one tardy (T). Students are responsible for following through and verifying that the selected option has been completed. All no grades (NG) must be made up by the end of the quarter in which they were earned. Should parents/guardians have concerns

regarding extenuating circumstances that result in a student exceeding the allowed number of absences, please call the school to make an appointment to meet with your student's assistant principal.

#### **OPTIONS:**

- **Engagement Time Sessions:** 7:10 A.M.-7:40 A.M. Students will complete the necessary amount of time needed with the teacher in whose class the student received an NG. The teacher will sign the attendance form and the student will return the form to the Attendance Office within 3 days.
- **Perfect Attendance:** 10 consecutive school days in all classes, including no tardies, will clear one NG within the quarter it was earned. School activities (N) and excused absences (E) do not count against the 10 days of perfect attendance. Students will have the Attendance Office verify and sign the attendance form within 3 days.
- **Hawk Study Hall:** Study Hall sessions will be offered during the last week of each quarter, after-school on designated days. Study Hall schedules will be available in the Attendance Office, on the Alta High website and posted throughout the building. Hawk Study Hall sessions start promptly at 3:00 P.M. and 4:00 P.M. If a student is late to a session, he/she will not be admitted. It is recommended that students arrive five minutes prior to the start of a session. Tardies must be made up within the first half hour of each session.
- For admittance into a session of Hawk Study Hall, students must have previously purchased a ticket in the Main Office, one ticket for each attendance mark they are making up, \$3.00 per ticket. Students must also bring their photo ID and have appropriate school work. No food, drink or electronic device will be permitted in the Study Hall area. No sleeping or communicating with other students will be allowed during the session. All Alta High School rules will be enforced in each session. A student who is disruptive or who violates the above rules during Hawk Study Hall will be asked to leave the session by the supervising teacher. The student will also forfeit the money and attendance for that session.
- Each time a student attends Hawk Study Hall, he/she will be given a yellow receipt. This receipt verifies the date and time spent in Study Hall and the class period the student chose for makeup. It is highly recommended that students retain their copy of the yellow slip in case a discrepancy arises. All attendance discrepancies can be resolved with the Attendance Office personnel.

- *This Attendance Policy may be revised at any time during the school year.*
- *Any changes that are made to this policy will be clearly communicated to students, parents and staff.*

## Student Policies

Due to ongoing policy changes, student policies may be found at the  
Canyons District website <http://policy.canyonsdistrict.org/index.php/student-policy>

<b>POLICY #</b>	<b>STUDENT POLICY</b>	<b>POLICY #</b>	<b>STUDENT POLICY</b>
500.01	NONDISCRIMINATION	500.24	STUDENT EDUCATION TRAVEL
500.02	EXHIBIT 1	500.26	STUDENT AUTOMOBILE USE AND PARKING
500.02	EXHIBIT 2	500.27	ATHLETE AND STUDENT HEAD INJURIES
500.02	STUDENT CONDUCT AND DISCIPLINE	500.27	EXHIBIT – 1 – CONCUSSIONS AND SYMPTOMS
500.03	SECTION 504 OF THE REHABILITATION ACT	500.28	HIGH SCHOOL YEARBOOK
500.04	REPORTING CHILD ABUSE / CHILD PROTECTION	500.29	EYE PROTECTION
500.05	EXHIBIT 1	500.30	OPEN ENROLLMENT AND SCHOOL MORATORIUMS
500.05	EXHIBIT 2	500.31	ADMISSION PROCEDURES (ELIGIBILITY TO ATTEND SCHOOL)
500.05	REPORTING STUDENT SAFETY	500.32	ADMISSION OF NONRESIDENT STUDENTS
500.06	TECHNOLOGY RESOURCES: NETWORK ACCEPTABLE USE (STUDENTS)	500.33	OUT OF DISTRICT STUDENTS (PART-TIME AND ACTIVITIES)
500.07	SEARCH AND SEIZURE	500.34	IMMUNIZATION OF STUDENTS
500.08	EXHIBIT – 1 – FERPA ANNUAL NOTIFICATION	500.35	STUDENT ATTENDANCE
500.08	EXHIBIT – 2 – MILITARY AND COLLEGE RECRUITING OPT – OUT	500.40	STUDENT HEALTH SERVICE AND REQUIREMENTS
500.08	EXHIBIT – 3 – RETENTION SCHEDULE SCHOOL RECORDS	500.41	DISTRICT NURSES
500.08	STUDENT RECORDS, PRIVACY RIGHTS, AND RELEASE OF INFORMATION	500.42	ADMINISTERING MEDICATION TO STUDENTS
500.09	PUBLICATIONS – SPEECH AND MANNERS	500.43	VISION SCREENING
500.10	RELEASED TIME CLASSES AND PUBLIC SCHOOLS (RELIGIOUS INSTRUCTION)	500.44	STUDENT HEARING CONVERSATION PROGRAM
500.11	SPECIAL EDUCATION FOR STUDENTS WITH DISABILITIES	500.46	EXHIBIT - 1 - HOME INSTRUCTION
500.13	LIFE WITH DIGNITY ORDERS	500.46	HOME AND HOSPITAL INSTRUCTION
500.20	EXHIBIT – 1 – STUDENT CLUB FORM		
500.20	STUDENT CLUBS		
500.22	STUDENT FEES, FINES, AND CHARGES (WAIVERS)		

### **Hall Passes**

Students shall not be allowed out of class without a hall pass.

Students shall not receive assistance in the office areas without a hall pass.

### **Insurance**

Student insurance is available to all members of the student body at a minimal cost. CHIP information is located in Alta High's main office. It is highly recommended all students have some type of health and accident insurance. Neither the school nor the Canyons School District Board of Education is an insurance agent nor does the school or the district carry insurance on individual students. The district does provide the opportunity for an insurance company to serve students. Students participating in athletics must have insurance coverage.

### **Lockers**

Students who opt to purchase a locker will be subject to the following:

#### **Locker Security**

In order to protect your locker items, it is critical for students to adhere to these rules:

Stay in your assigned locker.

Do not give out your locker combination to other students!

Do not leave valuables in your locker.

#### **Care of Locker**

Lockers are school property. Students are responsible for keeping lockers clean both inside and out. Any damage such as writing, scratches, or dents may result in the loss of locker privileges and students may be required to pay a fine for vandalism. Students are responsible to notify the Attendance Office if their locker is in need of repair or if it has been vandalized. Students will be held responsible for any unreported damage to their lockers.

#### **Locker Searches**

School officials reserve the right to search any or all school lockers at any time. Any item found in a school locker, which are of an illegal or inappropriate nature will result in disciplinary action. A complete copy of disciplinary actions can be found in CSD Policy 500.07

#### **Loss of Personal Property**

Canyons School District is not responsible for any personal property that is lost or stolen, which may have been stored in a student locker or gym locker. There is no provision, which allows payment for any personal item that is taken from a student locker.

### **Lost and Found**

Items left in the dance room, will be held in that area. Items left in the gym area, will be held in either the women's or the men's dressing area. After approximately a week the item will be moved to the Lost and Found cabinets located in the attendance office. Items left in other areas of the building will be held in the Attendance Office.

At the beginning of each quarter and one week following the close of school, items that have not been claimed will be donated to charity.

## **Cashing and Change Policy**

The school does not cash checks. We accept checks and cash only for the exact amount of registration fees and approved school expenses. We do not accept two-party or out-of-state checks. **Insufficient funds checks will be turned over to a collection agency for processing and collection.** Change is not made in the main office. There is an ATM machine located outside of the main office for student convenience. Credit Card/Debit payments are only accepted currently through your skyward account online.

## **Fines**

Fines will be assessed to cover the cost of damage or loss of school property such as books, desks, etc. A fine for vandalism will be assessed and the cost of repairs/replacement will be assessed to the student. Fines may also be viewed and paid online with a credit card through the student's Skyward fee management. If a student has a fine, statements will be emailed or mailed multiple times throughout the school year. **Fines that are not paid, will be sent to a collection agency for processing and collections.**

**Senior Cap, Gown and Yearbooks will be withheld from students until all fines are paid.**

## **Refunds**

### Students Transferring Out of the District

1. Fees are fully assessed and fully refundable for the first week of the school year.
2. The school will issue a check or online refund according to refund schedule (available in the main office). After the first week of school, checks or online refunds are to be issued to the students' parent/guardian and/or mailed to them per their request.
3. A student's activity card must be returned to receive the activity fee refund.

### Students Transferring Within the District

1. If a student has a fee waiver agreement, it will be forwarded to the school receiving the student when requested.  
The yearbook fee is refundable to students who withdraw from school before October 30.
30. All other fees are not refundable.

**Fundraising funds are non-refundable and non-transferrable.**

## **School Lunch and Breakfast**

Students eat lunch in the Commons Area. A well-balanced breakfast is offered at a cost of \$1.10; lunch is offered to students at a cost of \$2.00\* per day. Additional items are available for students wishing to purchase single food items. Prices range from \$.50 to \$3.00. They can also purchase a second lunch for \$3.50

All those eating school lunch/breakfast are expected to:

- (a) dispose of all lunch litter in waste cans
- (b) leave the table and floor clean, and
- (c) return trays to the dishwashing area.

Students who fail to comply with these rules of common courtesy (such as throwing food, and sitting or walking on tables) will be requested to assist in cleaning the Commons Area and may lose school lunch privileges. Repeated or serious offenses may result in suspension/parent conference, etc.

**\*Lunch prices are subject to change**

## **Comprehensive Guidance Program**

Students and parents can make an appointment to see a school counselor on an individual basis throughout the school year. School counselors can guide students in the areas of academic planning, career guidance, and personal concerns.

Each year, every student and his/her parent's meet with a school counselor to discuss the student's ***Plan for College and Career Readiness***. During the Plan CCR topics discussed include: graduation requirements, 4-year high school planning, college entrance requirements, college planning and selection, career center resources, student services, grades, test taking strategies, and academic testing.

## **College and Career Ready Timeline**

### **Freshman Year**

Attend your Plan CCR meeting and update your 4-year high school plan. Attend classes and complete schoolwork. Ask for help when you struggle.

Keep grades high for the best GPA and class rank. Get involved in school activities, leadership opportunities, and community service. Investigate and explore how your interests and abilities relate to careers. Create a college and career folder to keep track of all grades, awards, and involvement activities.

### **Sophomore Year**

Attend your Plan CCR meeting and update your 4-year high school plan. Attend classes and complete schoolwork. Ask for help when you struggle. Keep grades high for the best GPA and class rank. Get involved in school activities, leadership opportunities, and community service. Create a resume of your skills and experience, track grades, awards and involvement activities for your college and career folder.

### **Junior Year**

Attend your Plan CCR meeting and update your 4-year high school plan. Attend classes and complete schoolwork. Ask for help when you struggle.  
Keep grades high for the best GPA and class rank.  
Get involved in school activities, leadership opportunities, and community service. Take the ACT test. Use your results to maximize your academic strengths.  
Examine your abilities and interests and how they relate to careers. Explore careers, colleges, universities, and other training programs.  
Investigate and tour colleges with academic programs of your interest.  
Update your resume and continue tracking grades, awards, and involvement activities.

## Senior Year

Attend your Plan CCR meeting and update your 4-year high school plan. Attend classes and complete schoolwork. Ask for help when you struggle. Keep grades high for the best GPA and class rank. You may (optional) register to take the ACT test multiple times. Check college requirements to see if they require the SAT test. Visit colleges that have academic programs of your interest. Attend Alta's college day and other regional college and financial aid/scholarship presentations. Explore scholarship opportunities. Most scholarships are awarded from the college you chose to attend and are based on merit, leadership, diversity, and talent. There are many private organizations that fund scholarships. Visit Alta's website for more financial aid/scholarship information:  
[www.ahs.canyonsdistrict/counseling.org](http://www.ahs.canyonsdistrict/counseling.org)

Register for the FAFSA (Free Application of Federal Student Aid) at [www.fafsa.gov](http://www.fafsa.gov). Many scholarships require completion of the FAFSA. Apply to colleges. Pay close attention to DEADLINES! Send transcripts, test scores, and letters of recommendation to the colleges of your choice. Use the information from your college and career folder to complete college and scholarship applications. If you need a letter of recommendation from a teacher, give them a resume and enough time to write a letter for you.

## High School Graduation Requirements

### Class of 2023

4	English Language Arts
3	Math (minimum of Algebra 1 or Common Core Math 1)
3	Science (two of three must be from: Earth Science, Biology, Chemistry, Physics)
3.5	Social Studies (.50 Geography, .50 World Civilizations, 1 US History, .50 Gov't, .50 Elective Social Studies)
2	P.E./Health
1.5	Fine Arts
1	Career & Technical Education
.50	Computer Technology
.50	Financial Literacy
9.5	Electives
28	Total Credits

### **Advanced Diploma**

#### *College and Career Readiness*

Standard Diploma requirements including completion of Math through Algebra 2 or Common Core Math 3, two of the three sciences must come from: Biology, Chemistry, or Physics, **and** 2 years of the same World Language (grades 8-12). Minimum GPA : 2.0

### **Honors Diploma**

#### *College and Career Readiness*

Advanced Diploma requirements including meeting benchmark scores on the ACT. Students must meet the following benchmark scores on the ACT test: English 18, Reading 21, Math 22 and Science 23. Minimum GPA: 3.0

## **PLAN CCR**

Each year every student and his/her parents will meet with a guidance counselor or another trained educator to discuss students college/career readiness. During this meeting the following items will be covered:

- Progress toward graduation
- Review of educational assessments (SAT, ACT, JCT, etc.)
- Career field selection
- Review of 4-year plan and confirmation of course selection for the following year as it relates to career field selection.

## **Class Changes**

It is important for a student to make wise decisions when registering for classes, based upon his/her PLAN CCR, graduation requirements and future goals of both work and education.

Students will be able to access their schedules in August after their registration is completed. At that time, Alta will have a window of approximately 5 days, where students will have the opportunity to make changes to their schedule.

The only time a class change is made outside of the scheduling windows is for unusual circumstances in collaboration with a parent, teacher, administrator, counselor, and student where the situation presents itself as a necessary change. Some examples could include: a medical condition or situation, a student that has transferred to Alta from out of district, or a student that is in a class which is not an appropriate level.

## Testing

TEST	WHAT IS IT FOR?	WHO TAKES IT?
ACT	College admission test – Saturday test dates on actstudent.org All Juniors will take in Spring of Junior Year	Junior/Senior
AP TESTS	Earn college credit with a passing score	AP Students
PSAT/NMSQT	National Merit Scholarship qualifying test	Sophomores (practice/optional) Juniors (qualify)
ASPIRE		Freshman / Sophomores
SAT	College admission test – Pre SAT	Junior / Senior
CPT	College placement test for admitting students to concurrent enrollment classes	Junior / Senior

### Parent Teacher Student Association (PTSA)

Alta encourages all parents, teachers, and students to join the PTSA. The PTSA provides many services to the school and allows the entire Alta community to have input into improving Alta High. The dues for PTSA are \$10.00 and may be paid during online registration or separately in the main office

---

## **Step2TheU**

# **An Early College Pathway in Partnership between Alta High School and the University of Utah**

---

### Program Overview

---

#### **What is Step2TheU?**

Alta High School is proud to announce a new innovative university partner initiative with the University of Utah, a tier-one research PAC-12 institution, which allows students to take an integrated approach to learning focused on Culture, Leadership, and Global Citizenship.

Step2TheU allows current juniors in high school to apply for (and upon acceptance) participate in an early college experience by taking 30 semester hours between summer after junior year through summer after senior year of high school. Students take four general education classes each summer with a Concurrent Math class fall and spring of senior year. Students are accepted through a comprehensive application process based on a student's GPA, the types of classes taken during 9<sup>th</sup>, 10<sup>th</sup>, and 11<sup>th</sup> grade (i.e., Honors, AP, and Concurrent Enrollment), essay response and student narrative, student achievements, personal attributes, participation in school, and other demonstrated leadership responsibilities. Further details are outlined on the application.

#### **Benefits:**

- Opportunity to take university classes from university professors
- Earn 30 semester university credits and 3 full high school credits
- Access general education classes in a class size and single cohort of 35-40 students
- Save approximately \$15,000 in tuition and other associated college fees
- Reduce the amount of time in university studies (up to a year and a half)
- Potential to graduate with a Bachelor's Degree in 2 ½ years
- Opportunity to network with university professors and conduct research on campus
- Attend Step2TheU unique campus activities (i.e., athletic events, specialized campus tours, tutoring, department tours, etc.)
- Engage in university learning in a common cohort with integrated curriculum

## Who can participate?

Step2TheU is available to current junior students only at Alta High School and students apply during their junior year.

---

## When and where are classes offered and what is the time commitment?

Students begin coursework the second week of June and finish the first week of August. Classes will be held three days a week (i.e., Monday, Wednesday, and Thursday) for six hours a day. All classes will be at the new Sandy University of Utah Extension Campus (10000 S. and just west of State St.)

<p style="text-align: center;"><b>Summer One - 2020</b> (between Junior &amp; Senior year – 12 Hours) Each class is 3 semester credits</p> <p><b>Writing 2010 (WR1):</b> Erin Rogers</p> <p><b>Behavioral Science 2001 (BF):</b> Jose Hernandez Zamudio</p> <p><b>Communication 1270 (HF):</b> Loretta Rowley</p> <p><b>Art 1015 (FF):</b> Miguel Galaz</p>	<p style="text-align: center;"><b>Summer Two – 2021</b> (after graduation – 12 Hours) Each class is 3 semester credits</p> <p><b>American Institutions (AI):</b> Faculty TBD</p> <p><b>Behavioral Science (BF):</b> Jose Hernandez Zamudio</p> <p><b>Science (SF or AF):</b> Faculty TBD</p> <p><b>Communication 3460 (CW/HF):</b> Loretta Rowley</p>
<p style="text-align: center;"><b>Fall 2020 Senior Year</b></p> <p><b>Mathematics (1030, 1040, 1050, or 1060):</b> UofU Online or SLCC CE (Alta)</p>	<p style="text-align: center;"><b>Spring 2021 Senior Year</b></p> <p><b>Mathematics (1030, 1040, 1050, or 1060):</b> UofU Online or SLCC CE (Alta)</p>

## What is the learning philosophy of Step2TheU?

Student Success at the University of Utah is captured in the Utah Pledge. The Utah Pledge highlights the importance of learning communities, mentors, advisors, financial planning and deeply engaged learning experiences. Step2TheU activates three elements of the Utah Pledge. Step2TheU uses integrated and applied learning as primary learning outcomes. Each summer provides an integrative, thematically oriented, pathway (i.e., Culture and Leadership) through General Education. Step2TheU also offers wrap around support from a peer mentor, a student success advocate and a University College Advisor. Students will finish work with a meaningful culminating integrated project. Step2TheU

allows for students to complete most or all of their

General Education requirements in one year (with two additional classes being waived if students opt to attend the UofU). All faculty included in this program have been selected because of their demonstrated commitment to student success and prior work and understanding of working with high school aged students.

**Contact Information:**

Alta High School Counseling Center 801-826-5620

## **Parking**

Utah State law permits each school district and school within the district to designate parking areas and that those parking areas may have rules enforced by school personnel as well as local law enforcement. At Alta High School, the southwest parking lot and designated sections of the west parking lot have been allocated for student parking.

Each vehicle parked at Alta High School must have a current school year parking permit properly displayed. Parking Contracts are available in the Main Office or online through online registration. Permits cost \$10.00 each. Due to limited parking space, only junior and senior students will be issued parking permits. Permits MUST be displayed properly. Failure to properly display a permit will result in a parking ticket with a fine.

Each permit holder must have a valid Utah driver's license. Those students who park in the parking lot must obey all rules and state laws. In addition, each student must provide written permission from a parent/guardian to drive a motor vehicle to school. In accordance with state laws, vehicles without a parking permit that is appropriately displayed may be ticketed, tagged with a sticker, booted, or towed at the owner's expense. Any unpaid tickets/fines may be sent to our collection agency.

The student's vehicle may be searched when on school property if school authorities have reasonable suspicion that materials in violation of federal, state, county, municipal, or school codes are stored within the vehicle. Any such materials or other improper items found during the course of the search may be seized and used as evidence in school disciplinary hearings and legal proceedings.

Students who illegally park in the faculty reserved area, in the visitors parking area, in handicapped parking, or in any "no parking" zone will be ticketed, booted, and/or towed. Any unpaid tickets/fines may be sent to a collection agency.

Repeat offenses (more than 4 tickets) may result in being booted or towed at the owner's expense.

All cars parked on the drivers' education range must be moved by 3:00 p.m. Cars not moved are subject to towing.

### Drop Off/Pick-up Zone

Due to construction during the 2019-20 school year, student drop off is in the student parking lot. The east parking lot is reserved for staff parking only and not for student dropoff. The bus zone is for buses only, no student pick up or drop off is allowed in this area.

Due to our limited parking area, we need to have total cooperation from all student drivers and their parents. Students would be wise to take advantage of car-pooling and / or district buses and limit driving to necessary situations.

## Student Clubs & Organizations

Alta High School offers students the opportunity to belong to and form multiple types of clubs for all interests. There are clubs associated with academic curriculum as well as non-curricular clubs. Students are able to join clubs throughout the school year. During the month of September Alta will hold club rush week where students are able to visit different club tables to learn about and join any club. We encourage all students to be engaged and join a club. If there is not a club that interests a student a new club can be formed prior to October 1<sup>st</sup> 2022. A club has to have a charter, an advisor, and at least 7 members to be considered for club status. Below is a list of some clubs Alta offers:

Academic Decathlon

HOSA

Anime Club

Improv Club

Art Club

Interact Club

ASL

Key Club

Book Club

Math Club

Chess Club

Model UN

Chinese Club

Mountain Bike Club

DECA

National Honor Society

Drama Club

National Technical Honor Society

FBLA

Pinata Club

FCCLA

Polynesian Student Association

First Robotics

Rock Climbing

French Club

SheTech

GSIA

German Club

Happydings Club

Hawkappella

Hockey Club

## **Report Cards**

Report cards will be available on Skyward to students at the end of each quarter.

## **Visitors**

A visitor is defined as anyone who is not a registered student or Canyons District employee assigned to Alta High School.

Alta High has a “No Visitor” policy, except those that have been invited to speak or help in a classroom, or others conducting school business. All visitors must sign in and receive a visitor’s badge from the Attendance Office (7:00 a.m. - 3:00 p.m.). Violators visiting during school hours may be issued a trespass citation.

Children are not to be brought to the high school by their older brothers and sisters during the regular day.

## **Work-Based Learning**

Work-Based Learning (WBL) provides students with career awareness, career exploration and career pathway preparation for K-12 students. Through the Work-Based Learning opportunities students will be able to make better decisions leading to scholastic student motivation and improved post-secondary prospects. These opportunities will be presented through the following Work-Based Learning activities:

- Student internships
- Career Fairs
- Job Shadows
- Guest Speakers
- Field Studies
- Apprenticeships

Our vision is to support students with career skills and knowledge that will enable them to plan for their futures.

